

SP

VT7QC 1 - 022 - 1 R 00 - B 1 - 00 \*

**Series**

**Mounting**

- 1 - SAE B
- 2 - SAE C

**Camring**

(Delivery @ 0 bar & 1500 rpm)

* 003/B03/Y03 = 16.2 l/min	015/B15/Y15 = 75.1 l/min
005/B05/Y05 = 25.8 l/min	017/B17/Y17 = 87.4 l/min
006/B06/Y06 = 31.9 l/min	020/B20/Y20 = 95.7 l/min
008/B08/Y08 = 39.6 l/min	022/B22/Y22 = 105.4 l/min
010/B10/Y10 = 51.1 l/min	025/B25/Y25 = 118.9 l/min
012/B12/Y12 = 55.6 l/min	028/B28/Y28 = 133.2 l/min
014/B14/Y14 = 69.0 l/min	031/B31/Y31 = 150.0 l/min

\* '0' - Uni-directional 'B' - Bi-directional 'Y' - Bi-directional for cold start

**Type of shaft**

- 1 - Keyed (SAE B)
- 2 - Keyed (non SAE)
- 3 - Splined (SAE B)
- 4 - Splined (SAE BB)

**Modifications**

**Mounting W/connection variables**

	UNC		METRIC	
	00	01	M0	M1
P	1"	3/4"	1"	3/4"
S	1 1/2"			

**Seal class**

- 1 - S1 (for mineral oil)
- 4 - S4 (for fire resistant fluids)
- 5 - S5 (for mineral oil and fire resistant fluids)

**Design letter**

**Porting combination**

00 - standard

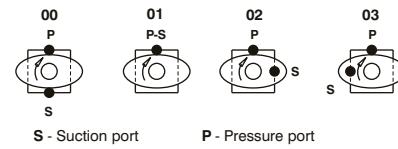

**Direction of rotation (view on shaft end)**

- R - clockwise
- L - counter-clockwise

**INTERNAL LEAKAGE (TYPICAL)**

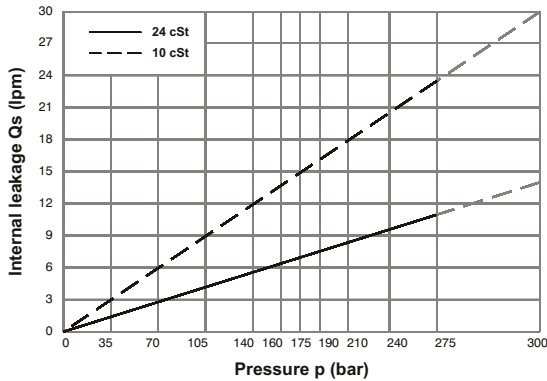

Do not operate pump more than 5 seconds at any speed or viscosity if internal leakage is more than 50% of theoretical flow.

**NOISE LEVEL (TYPICAL)**

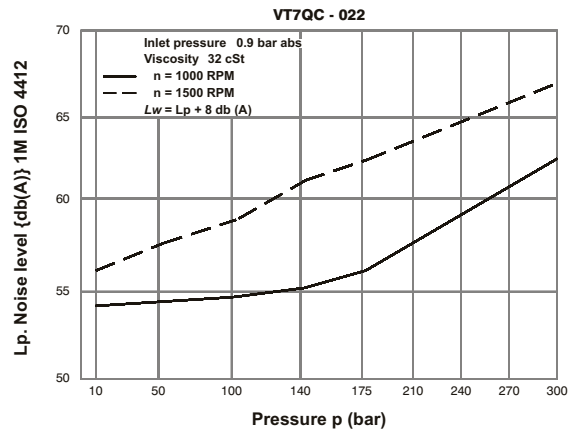

**HYDROMECHANICAL POWER LOSS (TYPICAL)**

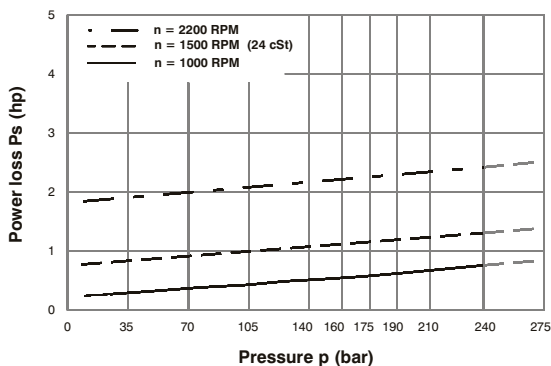

**PERMISSIBLE RADIAL LOAD**

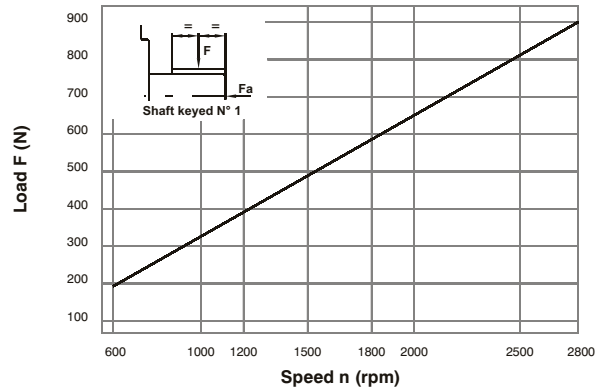

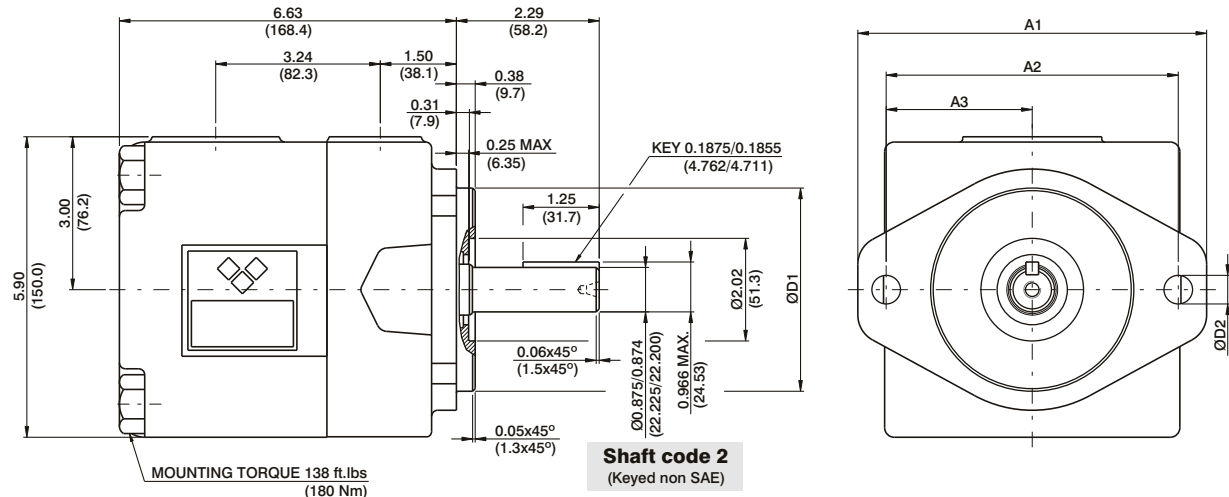
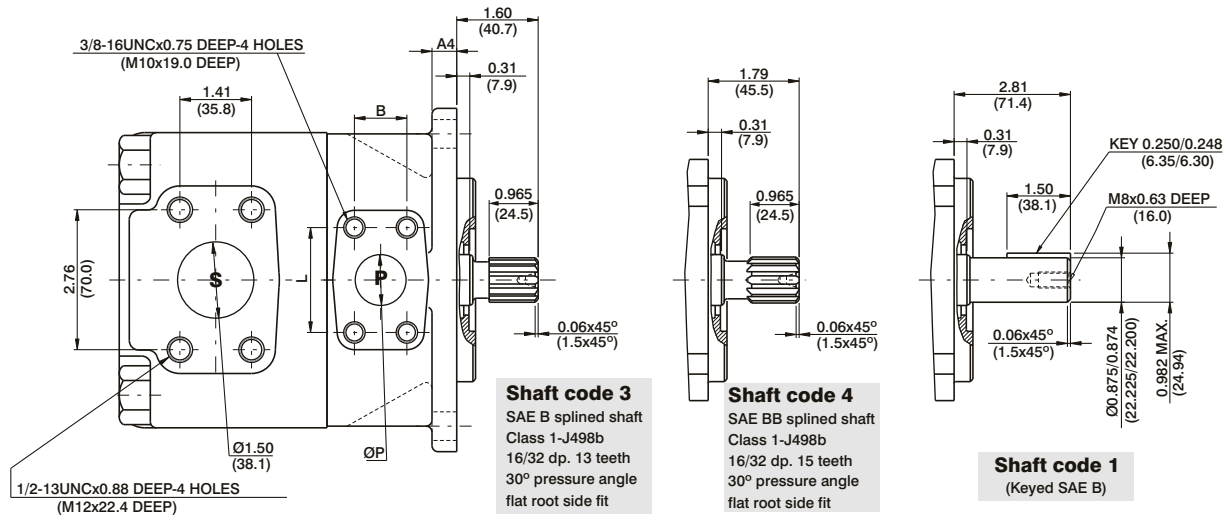

Mounting	VT7QC1	VT7QC2
	SAE B	SAE C
ØD1	4.000 (101.60) 3.998 (101.55)	5.000 (127.00) 4.997 (126.94)
ØD2	0.56 (14.3)	0.69 (17.5)
A1	6.87 (174.5)	8.36 (212.5)
A2	5.75 (146.0)	7.13 (181.0)
A3	2.87 (73.0)	3.56 (90.5)
A4	0.5 (12.7)	0.62 (15.7)

ØP	L	B
0.75 (19.05)	1.874 (47.6)	0.874 (22.2)
1.00 (25.4)	2.06 (52.4)	1.03 (26.2)

Shaft torque limits in <sup>3</sup> /rev x psi (ml/rev x bar)	
Shaft	Vp x p max.
1	14473 (16500)
2	12666 (14300)
3	18246 (20600)
4	19309 (21820)

## OPERATING CHARACTERISTICS - TYPICAL (24 cST)

Series	Volumetric Displacement Vp	Flow q (lpm) & n = 1500 rpm				Input power p (kW) & n = 1500 rpm			
		p = 0 bar	p = 140 bar	p = 240 bar	p = 300 bar	p = 7 bar	p = 140 bar	p = 240 bar	p = 300 bar
003	10.8 ml/rev	16.2	11.9	8.1	--	1.3	5.3	7.8	--
005	17.2 ml/rev	25.8	21.5	17.7	13.7	1.4	7.5	12.2	14.9
006	21.3 ml/rev	31.9	26.5	22.0	18.0	1.5	8.9	14.7	18.0
008	26.4 ml/rev	39.6	34.1	29.6	25.6	1.6	10.7	17.7	21.8
010	34.1 ml/rev	51.1	45.7	41.2	37.2	1.7	13.4	22.3	27.5
012	37.1 ml/rev	55.6	50.2	45.7	41.7	1.7	14.4	24.1	29.8
014	46.0 ml/rev	69.0	63.5	59.0	55.0	1.9	17.6	29.5	36.5
015	50.5 ml/rev	75.1	69.6	65.1	61.1	2.0	18.0	32.0	39.5
017	58.3 ml/rev	87.4	82.0	77.5	73.5	2.1	19.0	36.9	45.7
020	63.8 ml/rev	95.7	90.2	85.7	81.7	2.2	23.8	40.2	49.8
022 <sup>2)</sup>	70.3 ml/rev	105.4	100.0	95.5	91.5	2.3	26.1	44.1	50.3
025 <sup>1,3)</sup>	79.3 ml/rev	118.9	113.5	109.0	--	2.5	29.2	49.5	--
028 <sup>1,4)</sup>	88.8 ml/rev	133.2	127.7	124.5	--	2.8	32.7	48.5	--
031 <sup>1,4)</sup>	100.0 ml/rev	150.0	144.5	141.3	--	2.8	36.5	54.4	--

1) 025-028-031 = 2500 R.P.M. max.

2) 022 = 275 bar max. int.

3) 025 = 240 bar max. int.

4) 028-031 = 210 bar max. int.

-- Not to use because internal leakage greater than 50% of theoretical flow.